

## Features

- ✧ Electronically addressed. The address is modified in field.
- ✧ Built-in microprocessor can store 14 history records.
- ✧ Drift compensation, to suit environment changing extensively.
- ✧ Self-diagnostic.
- ✧ Standard: UL 268.

## Description

I-9102(UL) Intelligent Photoelectric Smoke Detector (the detector) can form fire alarm system connecting with fire alarm control panel. The detector illuminates indicators to indicate fire alarm status and transmits the fire signal to the control panel.

Using infrared scattering technology, the detector receives very weak infrared light under normal smokeless condition. If smoke particles enter the chamber, the received light signal will increase by scattering. When smoke density reaches a pre-set level, the detector will alarm out. In order to reduce interference and power consumption, the emitting circuit works in pulse mode to prolong the life of IR LED.

## Connection and Cabling

Fig.1 shows the detector bottom and Fig. 2 the base.

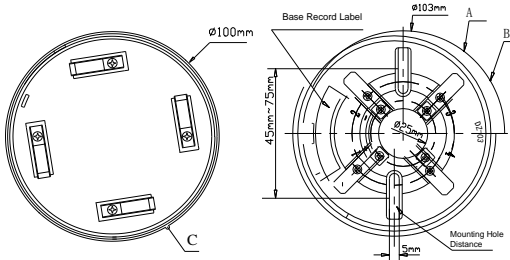

Fig. 1

Fig. 2

There are four conducting piece on the base, each carrying a terminal with numbers. The detector loop in the conduit can be connected with any two diagonal conducting pieces (polarity-insensitive). The other two are used to fix the detector accessorialy.

### Recommended Cabling

1.0mm<sup>2</sup> or above fire cable for detector loop, subject to local codes.

**UL Listed Compatible Control Panel:** GST-M200

## Installation

A fixed installation direction is ensured by the location elements on the detector and the base. Fix the base with two tapping screws, and then align mark C on the detector with A on the base, rotate the detector to align mark C with mark B (Refer to Fig. 1 and 2 for the position of the marks), the detector will be fitted to the base. Mounting of the detector is shown in Fig. 3.

## Application

The detector is applicable to hotels, restaurants, office buildings, teaching buildings, banks, warehouses, libraries, computer rooms and switch rooms, etc.

Address can be programmed through programmer in field. Refer to the P-9910B Hand Held Programmer Installation and Operation Manual for further details.

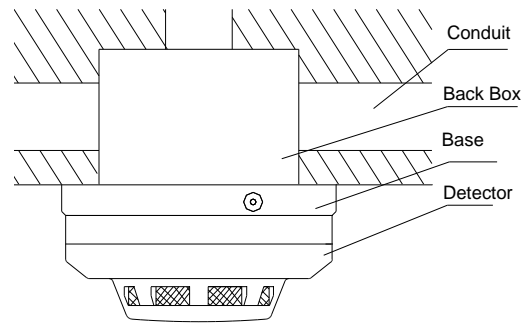

Fig. 3

## Testing

Before testing, notify the proper authorities that the system is undergoing maintenance, and will temporarily be out of service. Disable the zone or system undergoing maintenance to avoid unwanted alarms.

All detectors must be tested after installation and periodically thereafter. Testing methods must satisfy the Authority Having Jurisdiction (AHJ). Detectors offer maximum performance when tested and maintained in compliance with NFPA 72. The detector can be tested in the following way:

The Trutest model 300 Aerosol Smoke Detector Tester can be used for smoke entry testing. Set the generator to represent 4%/ft to 5%/ft obscuration as described in the Trutest manual. Using the bowl shaped applicator, apply aerosol until the panel alarms.

Additionally, canned aerosol simulated smoke (canned smoke agent) may be used for smoke entry testing of the smoke detector. Recommended aerosol smoke products are:

Manufacturer	Model
Trutest	AERO400
Home Safeguard Industries	25S
SDi	CHEK02 and CHEK06
SDi	SOLOA4
SDi	SMOKESABRE-01

When used properly, the canned smoke agent will cause the smoke detector to go into alarm. Refer to the manufacturer's published instructions for proper use of the canned smoke agent.

**Warning:** Canned aerosol simulated smoke (canned smoke agent) formulas will vary by manufacturer. Misuse or overuse of these products may have long term adverse effects on the smoke detector. Consult the canned smoke agent manufacturer's published instructions for any further warnings or caution statements.

When testing is complete, restore the system to normal operation and notify the proper authorities that the system is back in operation.

### Maintenance

1. The detector must be cleaned once a year to ensure normal operation of the system.
2. Before cleaning, notify the proper authorities that the system is undergoing maintenance and will temporarily be out of service. Disable the zone or system undergoing maintenance to avoid unwanted alarms.
3. Remove the detector from base. Use straight screwdriver to prize the top cover through three small grooves. Use a vacuum cleaner or cleaned, compressed air to remove dust and debris from the insect guard. If the dust is too much to clean up, you can remove the sensing chamber and pull the insect guard to clean or replace. Use a vacuum cleaner or cleaned, compressed air to remove dust and debris from the sensing chamber. Reinstall the sensing chamber and insect guard properly. Aligning the marks on enclosure, install the top cover again. Refer to Fig.4.

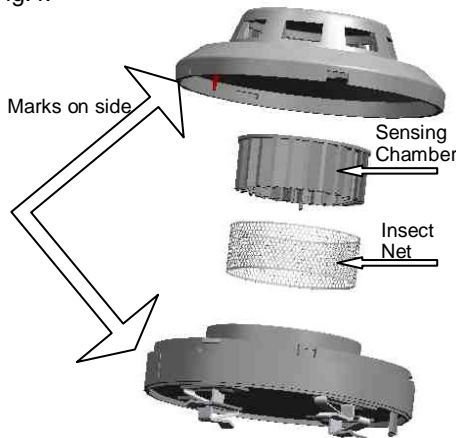

Fig. 4

4. The detector should be tested again after re-installed.

### Cautions

1. Dust cover can't be removed until the project is plugged. Protect the dust cover for the future use.
2. Dust cover provides limited protection against airborne dust particles. So, remove the detector prior to heavy remodeling or construction and inform the proper authority.
3. Be careful not to damage the detector in maintenance.
4. The smoke detector may not sense fire that where smoke cannot reach it, such as in chimneys, in walls, on roofs, or on the other side of closed doors.
5. The detector cannot monitor the place beyond protection area.

6. The detector may not warn you about fires caused by insufficient safety measures, violent explosions, leaking gas, improper storage of flammable materials like diluents and other safety hazards, arson or children playing with fire.
7. The alarm of a smoke detector used in high velocity environment will be delayed due to dilution of smoke by frequent and fast airflow.
8. The smoke detector cannot last forever. In order to keep the detector working in good condition, please maintain the equipment continuously according to recommendations from manufacturers and relative nation codes and laws.
9. The detectors must be tested regularly, at least once a year.

### Specification

Operating Voltage	Loop 24V(16V~28V)
Standby Current	≤0.8mA
Alarm Current	≤2.0mA
Indicators	Red, flash in normal, illuminate when alarming
Programming Mode	Electronically addressed
Code Range	One address within 1~242
Wiring	Two-wire, polarity-insensitive
Ambient Temperature	32°F (0°C)~100°F (+37.8°C)
Relative Humidity	≤95%, non condensing
Ingress Protection Rating	IP23
Material and Color of the Enclosure	ABS, White (RAL 9010)
Dimensions	Diameter 100mm Height: 42mm (without base)
Mounting Hole Distance	45mm~75mm
Weight	About 120g

### Accessories and Tools

Model	Name	Remark
P-9910B	Hand Held Programmer	Order separately
DZ-03(UL)	Base	Order separately

### Limited Warranty

**GST** warrants that the product will be free of charge for repairing or replacing from defects in design, materials and workmanship during the warranty period. This warranty does not cover any product that is found to have been improperly installed or used in any way not in accordance with the instructions supplied with the product. Anybody, including the agents, distributors or employees, is not in the position to amend the contents of this warranty. Please contact your local distributor for products not covered by this warranty.

This Data Sheet is subject to change without notice. Please contact GST for more information or questions.

### Gulf Security Technology Co., Ltd.

No. 80, Changjiang East Road, QETDZ, Qinhuangdao, Hebei, P. R. China 066004

Tel: +86 (0) 335 8502434 Fax: +86 (0) 335 8502532

service.gst@fs.utc.com www.gst.com.cn